

The energy-efficient
construction system



TERMALICA®

**Product
catalogue**

A photograph of a man and a woman embracing from behind, looking at a modern, multi-story house. The man is wearing a blue t-shirt and the woman is wearing a light blue top. The house has white walls, large windows, and balconies. The scene is set outdoors on a bright day.

TIME FOR A **WARM HOME**



AERATED CONCRETE

— The warmest wall construction material

The history of the birth of aerated, or porous, concrete, dates back to the year 1923, when the Swedish architect Axel Eriksson had developed the technology of hardening concrete blocks in autoclaves with the use of hot steam, and started industrial production of aerated concrete products. In Poland, the first experimental production line of aerated concrete products was opened in the year 1949, with industrial production commencing in the year 1951. Ever since, the production of this perfect product developed intensively, and in time, porous concrete became the most popular wall construction material.

Termalica porous concrete is manufactured out of a mix of raw resources: quartz sand, lime, cement, gypsum, water and a blowing agent, aluminium powder or paste. The tiny bits of aluminium, reacting with the calcium hydroxide, make the entire mass rise, creating millions of micropores in the concrete mass, with air trapped inside them. The production of aerated concrete components fits in with the idea of sustainable construction, and facilitates the protection of the natural resources of our planet. Thanks to the raising process, and the growing of forms, only about 0.2-0.3 cu m of raw material is necessary to create a cubic metre of ready aerated concrete. Precise control of raw resources

and an automated technological process with a computer-controlled dosing system ensure the production of high-quality, repeatable-characteristic material. The technical process allows precise planning of the density, thermal properties and mechanical resistance of aerated concrete by creating the right amount of air pores in it, even exceeding 85% of its volume.

The wall blocks and components are manufactured in several classes and thickness types: from 300 to 700 kg/cu m³. Thanks to its low density, porous concrete is characterised by outstanding thermal insulation properties, and is a perfect solution for energy-efficient construction.

According to statistical data published by the Polish Central Statistical Office for the year 2023, aerated concrete is the most broadly used wall material in construction in Poland. Its total share of the wall construction material marked in Poland exceeds 40%.

Termalica is a comprehensive system of components perfectly fitting in with each other, that allows one to construct an energy-efficient home, all the way from the foundations to the ceiling. It is made up of blocks to erect walls, window and door lintels, ceiling components and hollow concrete bricks for formwork construction. The blocks are available in diverse density classes, thanks to which one can erect both single- as well as multi-layer walls.

The components of the Termalica system are made of top quality aerated concrete – the material offering the best thermal insulation properties on the market. The blocks, making up the basic component of the wall erection system, are profiled with tongue and groove interlocking components, thanks to which their vertical seams do not require the use of mortar. Termalica blocks are a product conforming to the strictest requirements of the TLMB measurement class. This means that they fit in with each other almost ideally, thanks to which one can ensure that the wall that is erected is very homogeneous in terms of its core material, all of which results in a warmer home.

The perfect thermal insulation properties of aerated concrete allow one to construct single-layer walls of light block variations, classes 300, 350 and 400 kg/cu m. A house erected using **Termalica EKSTRA** or **Termalica KLASA** blocks requires no additional thermal insulation of polystyrene or mineral wool. The warmest wall component of the system are the energy-efficient **Termalica EKSTRA** blocks, having a thickness of 48 cm. They are characterised by an excellent heat transfer coefficient value of $U=0.16$ W/(m²K). In case of two-layer wall construction with the used of Termalica blocks, they also ensure a heat transfer coefficient that is 20-30% lower as compared to other wall materials.

Construct **COMPREHENSIVELY**



TERMALICA system components

■ solid foundation or slip stream

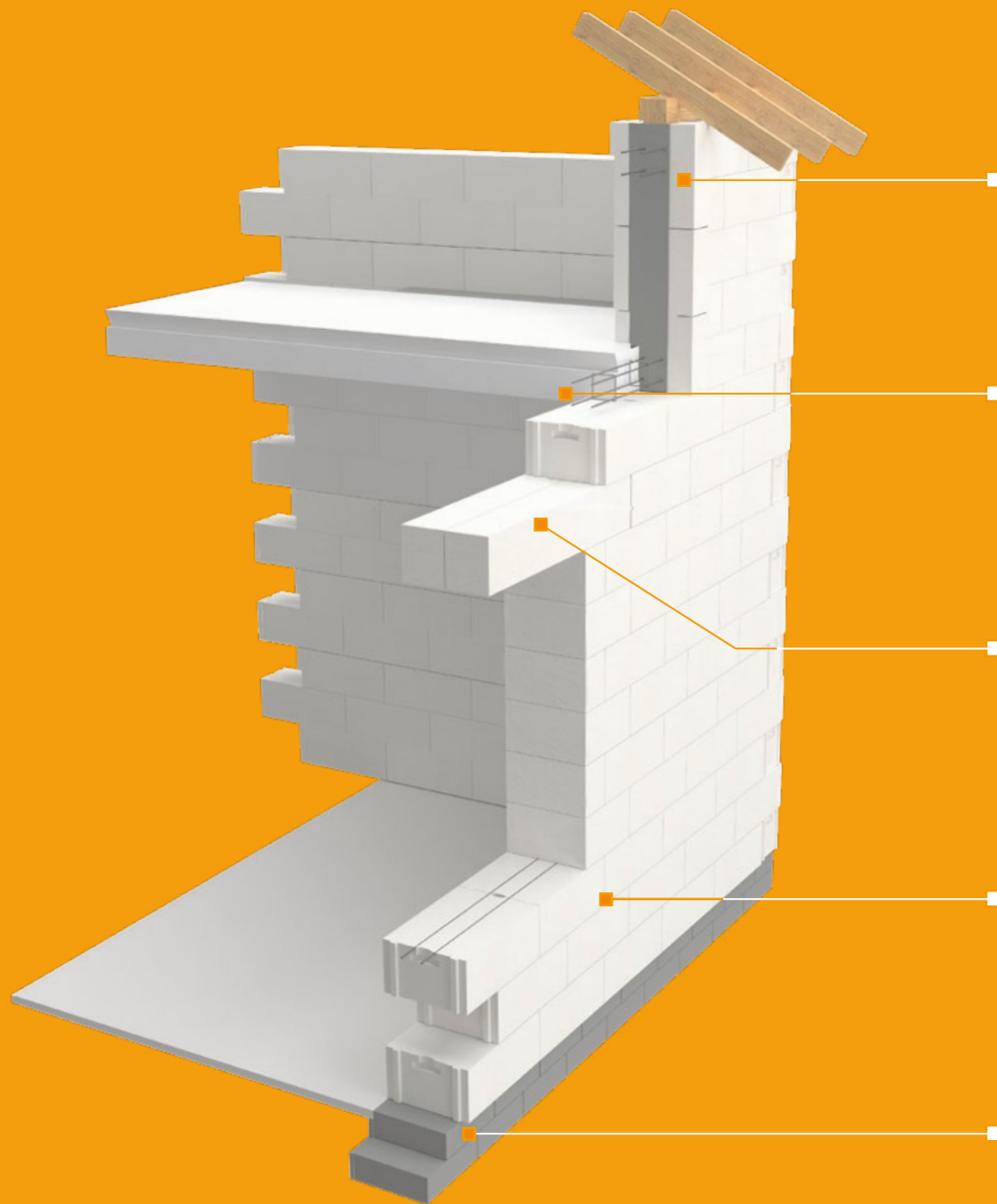

U-PROFILES



CEILING PANELS



LINTELS



BLOCKS

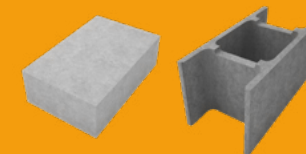

HOLLOW BRICKS AND FOUNDATION BLOCKS



Advantages of the system

Termalica aerated concrete

— an environmentally-friendly material

Sand, lime and water are the basic raw materials used to produce Termalica aerated concrete. The utilised natural resources provide it with its white colour. It does not contain any rejected production material such as volatile ashes, and it does not emit any hazardous compounds. The high technical and practical properties of the blocks are achieved by autoclaving, meaning, the curing and hardening in an atmosphere of concentrated steam and a temperature of 190 °C.

Production of Termalica forms facilitates the protection of our planet's natural resources. Only about 0.2-0.3 cu m of raw material is necessary to create a cubic metre of ready aerated concrete.

The technical process allows precise planning of the density, thermal properties and mechanical resistance of aerated concrete by creating the right amount of air pores in it, even exceeding 85% of its volume. Millions of evenly distributed air pores ensure perfect thermal insulation.

Wall components of Termalica aerated concrete are manufactured in line with standard PN-EN 771-4 „Specification for masonry units. Autoclaved aerated concrete masonry units.”

Termalica components are manufactured in classes that depend on the dry material volume density.

TERMALICA POROUS CONCRETE CLASSES	
Class	Density [kg/cu m]
TERMALICA 300	250 - 300
TERMALICA 350	300 - 350
TERMALICA 400	350 - 400
TERMALICA 500	450 - 500
TERMALICA 600	550 - 600
TERMALICA 700	650 - 700



U HEAT TRANSFER COEFFICIENT [W/M²K] DEPENDING ON THE WALL THICKNESS [CM]

Class	λ coefficient 10,D [W/mK]	U [W/m ² K] coefficient value of walls for $\lambda_{10,D}$					
		20	24	30	36,5	40	48
TERMALICA 300	0,075	-	-	0,25	0,21	0,18	0,16
TERMALICA 350	0,083	-	0,35	0,27	0,23	0,21	0,17
TERMALICA 400	0,09	-	0,37	0,30	0,24	0,23	0,19
TERMALICA 500	0,12	-	0,50	0,40	0,33	0,30	-
TERMALICA 600	0,14	0,70	0,58	-	-	-	-
TERMALICA 700	0,18	-	0,75	-	-	-	-

High thermal insulation properties

- the best material for energy-efficient construction

Termalica aerated concrete is characterised by excellent thermal insulation properties, and forms the best solution for energy-efficient construction. The parameter describing the thermal insulation properties of a material is the λ thermal conductivity coefficient [W/mK]. The lower the value of λ , the 'warmer' the material.

Aerated concrete gets its high thermal insulation properties thanks to its porous structure, composed of a material frame with millions of pores with air trapped inside, becoming the perfect insulator.

As the material density rises, the λ heat conductivity coefficient rises. The homogeneous structure of aerated concrete ensures high thermal insulation properties irrespective of the direction of the thermal flux, thanks to which one can reduce the heat losses due to cold foundation walls.

The warmest classes of aerated concrete are characterised, appropriately, by a λ thermal conductivity coefficient of 0.075 W/mK, 0.083 W/mK and 0.09 W/mK, and permit the construction of single-layer walls without the necessity of using additional insulation.

Diagram description: λ thermal conductivity of wall materials

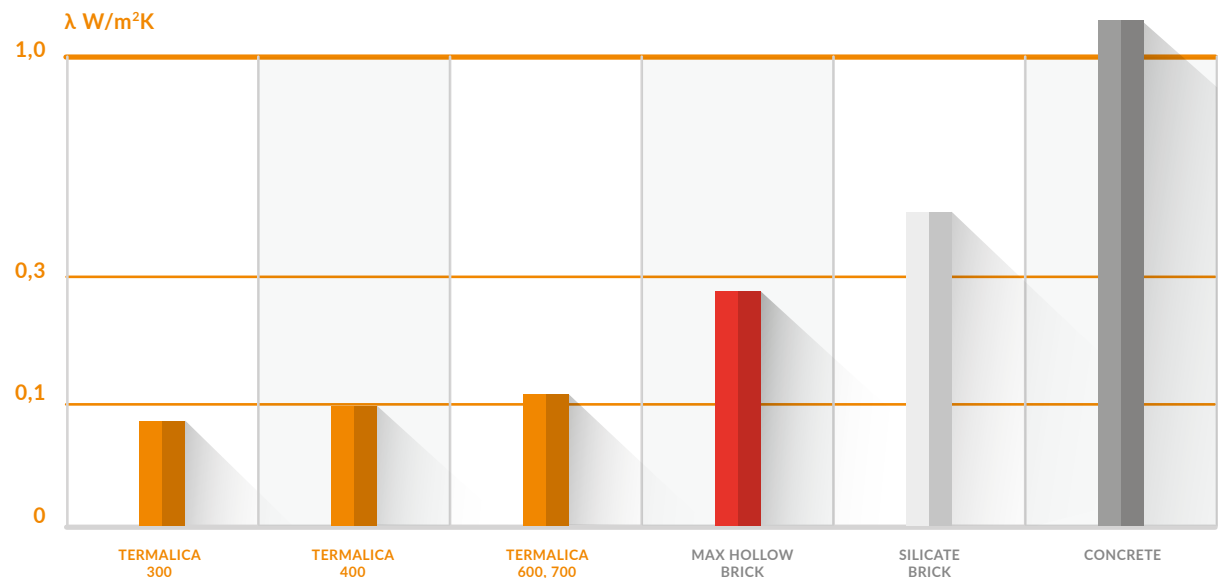

The parameter describing the thermal insulation capabilities of divider walls is the U heat transfer coefficient, the value of which depends on the type of material used, and its thermal conductivity coefficient $\lambda_{10,D}$, as well as the divider wall layer thickness. The lower the value of U, the better the thermal insulation properties of the wall.



Termalica ensures a comfortable room atmosphere

Lowest radioactivity

The production of Termalica aerated concrete using natural resources (sand and lime), without the addition of volatile ashes, as well as the lack of burning and high-temperature processing, ensures the achievement of lowest possible natural radioactivity indicators from among all wall construction materials.

Diagram description: **Natural radioactivity**

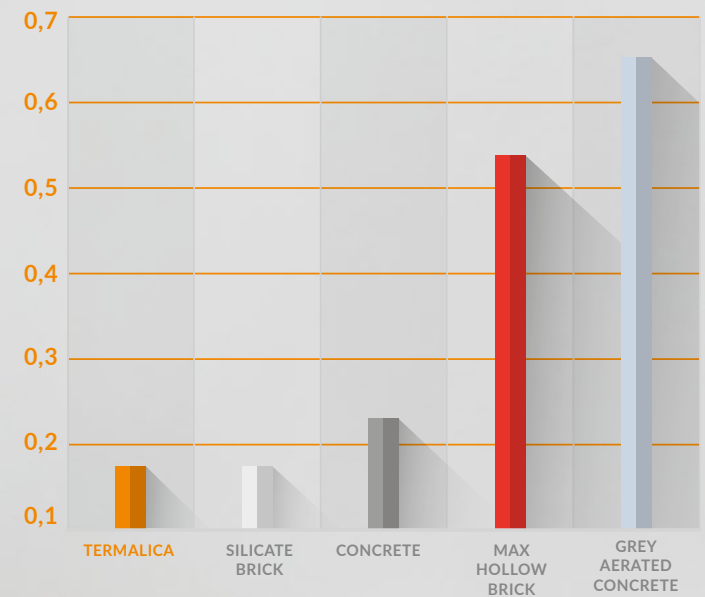

Thermal stability

Termalica aerated concrete walls, different than hollow brick walls, are monolithic and homogeneous, and have no air slits or gaps. This property ensures good thermal accumulation properties and high thermal inertia. Thanks to this, Termalica walls slowly release the heat accumulated inside, allowing one to maintain the room temperature at a fairly constant level, even in case of high outside temperature fluctuations. This is important particularly in the summer, when during warm days, the walls capture the heat and release it in the night, ensuring a stable interior temperature.



Optimum humidity

The high steam penetration ability of Termalica aerated concrete ensures the best, 'breathing' walls that stabilise air humidity in rooms. Walls materials with high steam penetration ability sport the capability of transporting steam from the inside to the outside, in case of any surplus humidity, and releasing humidity, in case the rooms would be too dry. The material steam penetration ability is defined by the diffusion resistance factor μ . For Termalica blocks, depending on the type, μ has a value of 2.8 to 5.3. The lower the value, the better the humidity transfer ability. The humidity of the construction material during use settles at a level of approximately 3% of mass during use, and is optimal for the well-being of the inhabitants.

Resistance to bacteria, mould and fungus

Production based on lime, and alkalinity of Termalica aerated concrete, ensure high resistance to biological corrosion, preventing the growth of bacteria, mould and fungus even in case of high humidity. Termalica is a material that also exhibits antiseptic properties.





Optimum load bearing capacity of bearing walls

The compression resistance of Termalica aerated concrete blocks, depending on the individual type, permits the erection of single-family house walls as well as multi-storey building walls.

TERMALICA AERATED CONCRETE CLASSES	
Class	Compression resistance [MPa]
TERMALICA 300	2
TERMALICA 350	2,5
TERMALICA 400	2,5
TERMALICA 500	3,0
TERMALICA 600	4,0
TERMALICA 700	5,0

Fire safety

Termalica aerated concrete is a non-flammable construction material, conforming to the criteria and requirements of the most demanding Euroclass, A1.

The fire safety of a building depends on the ability of a structure to conform to specific fire safety requirements within a set time period. The fire safety of a structure is described based on three basic criteria: load bearing capacity (R), insulation capacity (I) and tightness (E).

Aerated concrete wall fire resistance is classified depending on their thickness and load per standard PN-EN 1996-1-2:2010 (Eurocode 6. Design of masonry structures. General rules. Structural fire design).

Fire safety classification encompasses load-bearing walls and non-load-bearing walls, taking into account their maximum slenderness, composed of autoclaved aerated concrete, that conform to requirements of standard PN-EN 771-4.

FIRE RESISTANCE CLASSIFICATION OF TERMALICA AERATED CONCRETE WALLS PER STANDARD PN-EN 1996-1-2:2010

Wall thickness [cm]	Load		
	0	≤0,6	≤1
5	EI 30	-	-
7,5	EI 60	-	-
10	EI 120	-	-
12	EI 120	-	-
15	EI 180	REI 120	REI 120
20	EI 240	REI 240	REI 240
24	EI 240	REI 240	REI 240
30	EI 240	REI 240	REI 240
36,5	EI 240	REI 240	REI 240
40	EI 240	REI 240	REI 240
48	EI 240	REI 240	REI 240

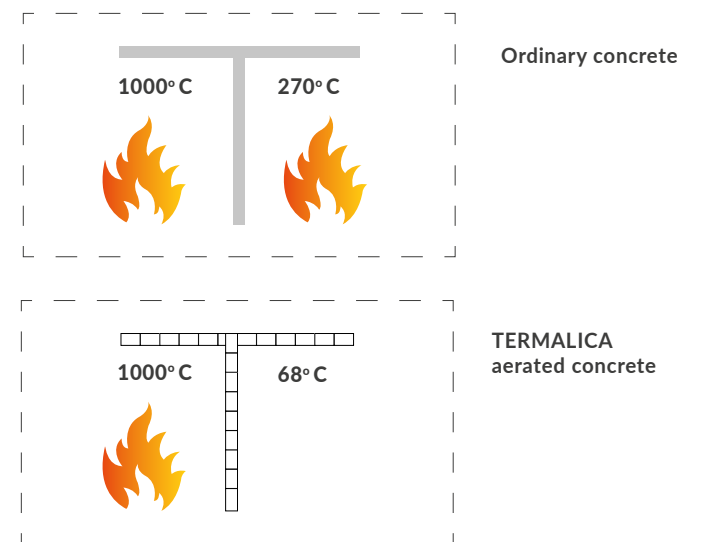

Acoustic insulation and noise protection

Acoustic insulation is the ability to dampen air-borne sounds. It depends on the mass of the material, its internal structure as well as the thickness and type of divider wall layers.

The homogeneous and porous structure of aerated concrete has acoustic insulation abilities better by at least 2 dB from other construction materials of a comparable dead weight.

R_{A1R} PROPER ACOUSTIC INSULATION EVALUATION INDICATORS FOR WALLS OF AERATED CONCRETE COMPONENTS WITH THIN JOINTS (INTERNAL WALLS)											
Class	R _{A1R} [dB] indicators depending on wall thickness [mm]										
	50	75	100	120	150	200	240	300	365	400	480
TERMALICA 300	-	-	-	-	-	-	-	40	42	43	44
TERMALICA 350	-	-	-	-	-	-	38	42	44	45	46
TERMALICA 400	-	-	-	-	-	-	41	44	46	47	-
TERMALICA 500	-	-	34	36	-	-	44	46	48	-	-
TERMALICA 600	30	33	36	38	40	44	46	-	-	-	-
TERMALICA 700	-	-	-	-	-	-	48	-	-	-	-

R_{A2R} PROPER ACOUSTIC INSULATION EVALUATION INDICATORS FOR WALLS OF AERATED CONCRETE COMPONENTS WITH THIN JOINTS (OUTSIDE WALLS)											
Class	R _{A2R} [dB] indicators depending on wall thickness [mm]										
	50	75	100	120	150	200	240	300	365	400	480
TERMALICA 300	-	-	-	-	-	-	-	36	39	40	42
TERMALICA 350	-	-	-	-	-	-	35	38	40	41	43
TERMALICA 400	-	-	-	-	-	-	38	40	42	43	-
TERMALICA 500	-	-	32	34	-	37	40	43	45	-	-
TERMALICA 600	30	32	33	35	36	40	42	-	-	-	-
TERMALICA 700	-	-	-	-	-	-	44	-	-	-	-



Termalica means savings on construction and life cycle costs

Faced with the decision of purchasing wall material, one has to factor in all utility properties and characteristics into its price, including, first of all, the thermal properties of the material and the relevant living comfort. Consider the total costs of erection of a square metre of walls with an assumed U heat transfer coefficient. Current technical requirements indicate a value not exceeding 0.20 W/m²K and the need of obligatory energy certification of buildings. Note, however, that it is always recommended to erect even warmer buildings, due to the possibility of marked reduction of life-cycle and heating costs. This is also very important in terms of the ever-rising electric energy and natural gas prices.

Building walls of Termalica materials, one saves on additional insulation, workmanship, mortar and plaster.

The Termalica construction system

The Termalica construction system covers products and components used for the erection of single-layer and multi-layer walls, ceilings, as well as the assembly of walls and roofs of industrial sites.

Termalica blocks

Termalica blocks all sport fixed and optimised dimensions: a height of 249 mm, a length of 599 mm, and a width depending on their foreseen use. The consumption of blocks per square metre of wall is just 6.67 pcs. The simplicity of wall erection is furthered by ergonomic mounting grips and interlocking joints that markedly reduce the wall erection time.

Termalica blocks are manufactured according to the strictest TLMB dimension precision class, with maximum permitted deviations of +/- 1.5 mm for length and width, and +/- 1 mm for height. Thanks to precise dimensions, the blocks only require 1-3 mm of thin-layer adhesive mortar for the horizontal joints. The use of thin-layer mortar ensures a homogeneous and even wall layer, and does not reduce thermal insulation properties. The vertical joints do not require mortar thanks to the tongue-and-groove interlock.

The blocks can easily be cut to size, sawed, bevelled and drilled in, thanks to which one can always implement any individual design when building, upgrading or refurbishing their home.

6.67 pcs. required per square metre

**Top dimensional precision class
- TLMB**

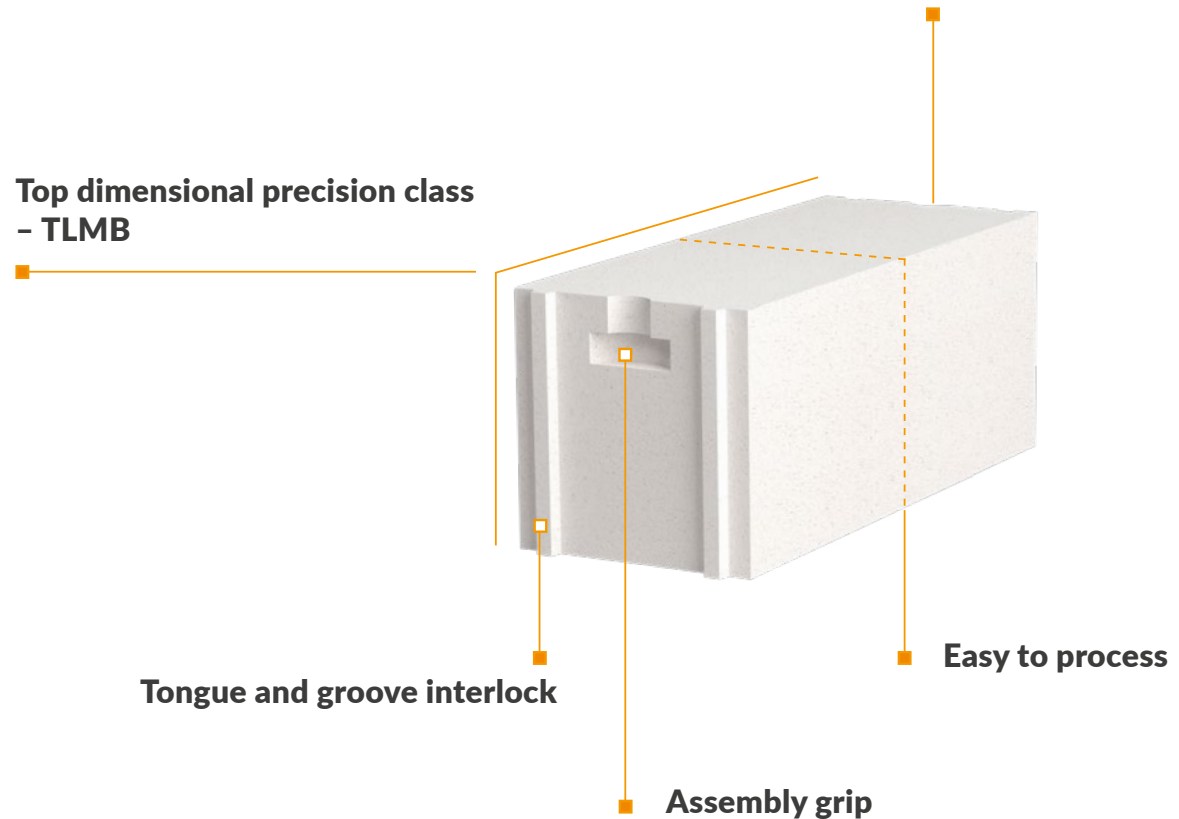

Tongue and groove interlock

Assembly grip

Easy to process

Outer walls

The warmest single-layer walls: **TERMALICA EKSTRA** and **TERMALICA KLASA**

Thanks to the precision fit of the individual aerated concrete components, single-layer walls are erected relatively quickly and cheap – mainly because of the lower work effort required and the lack of need of further insulation by mineral wool or polystyrene.

Single layer walls of the lightest block classes (300, 350) with thicknesses of 48, 40, 36.5 are a guarantee of perfect thermal properties.

The warmest single-layer wall made of TERMALICA EKSTRA blocks with a thickness of 48 cm allows one to attain a heat transfer coefficient value of $U=0.16 \text{ W}/(\text{m}^2\text{K})$.

TERMALICA KLASA are a set of blocks ensuring building energy efficiency.

For the erection of single-layer walls using TERMALICA EKSTRA and TERMALICA KLASA blocks, we recommend Termalica thin-joint mortar and system tools.

The warmest single-layer wall in the Termalica system, made with 48-cm-thick blocks, ensures a perfect heat transfer coefficient value.

$$U = 0,16 \text{ W}/\text{m}^2\text{K}$$

Advantages:

- ✓ Energy efficiency
- ✓ Construction speed
- ✓ Cost reduction
- ✓ Health
- ✓ Safety
- ✓ Work ergonomics

TERMALICA® EKSTRA

The best material for single-layer walls

TERMALICA® EKSTRA	Block thickness [cm]	Heat transfer coefficient U [W/m ² K] for λ _{10,D}	Mean compression resistance [MPa]
TERMALICA 300	48	0,16	2,0
TERMALICA 350	48	0,17	2,5
TERMALICA 300	40	0,19	2,0

TERMALICA® KLASA

Energy-efficient material

TERMALICA® KLASA	Block thickness [cm]	Heat transfer coefficient U [W/m ² K] for λ _{10,D}	Mean compression resistance [MPa]
TERMALICA 350	40	0,21	2,5
TERMALICA 300	36,5	0,22	2,0
TERMALICA 350	36,5	0,23	2,5
TERMALICA 400	40	0,23	2,5

Single-layer wall

Termalica blocks
EKSTRA

Termalica thin-joint mortar

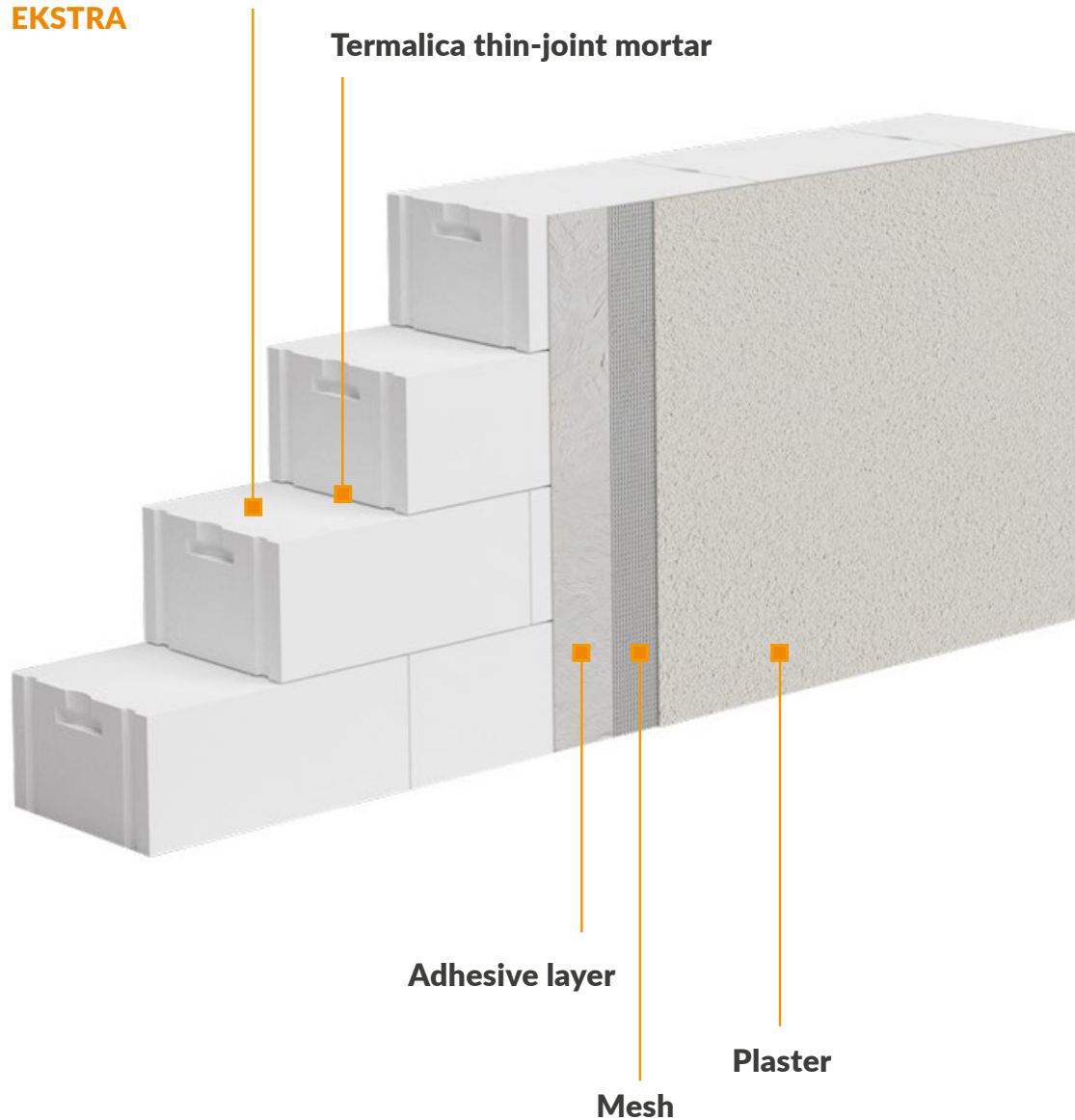

Adhesive layer

Mesh

Plaster

Proper bricklaying

1. We recommend the use of system tools:

- thin-joint trowel of an appropriate width
- smoothing float
- scraper
- chaser
- rubber hammer for block levelling

2. Lay out the first layer of blocks on ordinary mortar. Begin the laying by first arranging and levelling the blocks in the corners of the building (all of them should be at the exact same level).

3. After placing each layer, before applying thin-joint mortar, clean the top surface (using the scraper or float), and remove any dust.

4. After placing each layer, before applying thin-joint mortar, clean the top surface (using the scraper or float), and remove any dust.

5. For block trimming, use a hand or band saw.

More information can be found at www.termalica.pl and in the 'Termalica construction system' guide book.

Outer walls

Two-layer and multiple-layer walls

Multi-layer outer walls are most commonly two- or three-layer walls.

Two-layer partitions are made up of a structural load-bearing part made of Termalica type 400, 500, 600 and 700 blocks with thicknesses of 20, 24 and 30 cm, and a thermal insulation layer of mineral wool panels or polystyrene.

A three-layer wall has an additional shield layer of 9-12 cm made of aerated concrete blocks or ceramic bricks.

In case of a clinker facade, it is necessary to leave a ventilation layer of 3-4 cm between the insulation and shield layer.

In such construction systems as well, the 'warm' Termalica aerated concrete walls ensure the best insulation properties, wall smoothness and precision, limited consumption of mortar and faster construction as compared to other wall materials.

Thin-layer adhesive mortar or traditional mortar may be used for the erection of multi-layer walls.

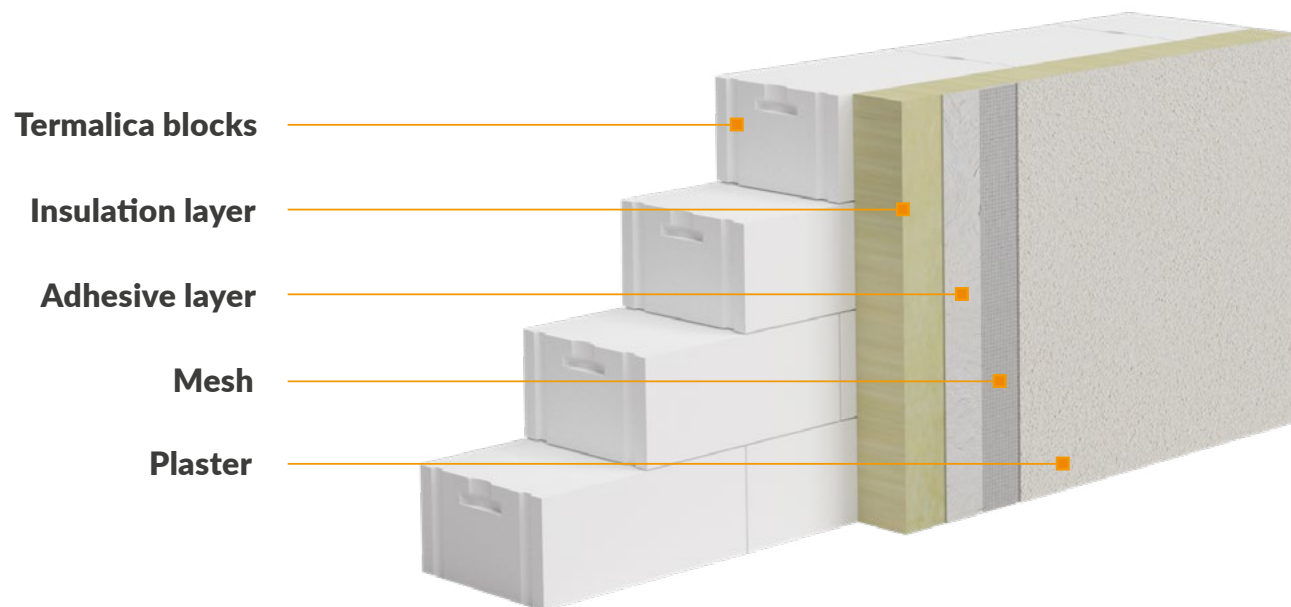

Block	Block thickness [cm]	Factor $\lambda_{10,D}$	U [W/m ² K] for $\lambda_{10,D}$ + insulating layer*	
			12	15
TERMALICA 300 T2/300-36,5/25/60 UZ TERMALICA® KLASA	36,5	0,075	0,13	0,11
TERMALICA 350 T2,5/350-40/25/60 UZ TERMALICA® KLASA	40	0,083	0,13	0,11
TERMALICA 350 T2,5/350-40/25/60 UZ TERMALICA® KLASA	36,5	0,083	0,13	0,12
TERMALICA 400 T2,5/400-40/25/60 UZ TERMALICA® KLASA	40	0,09	0,13	0,12
TERMALICA 300 T2/300-30/25/60 UZ	30	0,075	0,14	0,13
TERMALICA 400 T2,5/400-36,5/25/60 UZ	36,5	0,09	0,14	0,13
TERMALICA 350 T2,5/350-30/25/60 UZ	30	0,083	0,15	0,14
TERMALICA 400 T2,5/400-30/25/60 UZ	30	0,09	0,15	0,14

Block	Block thickness [cm]	Factor $\lambda_{10,D}$	U [W/m ² K] for $\lambda_{10,D}$ + insulating layer*	
			12	15
TERMALICA 500 T3/500-36,5/25/60 UZ	36,5	0,12	0,16	0,14
TERMALICA 350 T2,5/350-24/25/60 UZ	24	0,083	0,17	0,15
TERMALICA 400 T2,5/400-24/25/60 UZ	24	0,09	0,17	0,15
TERMALICA 500 T3/500-30/25/60 UZ	30	0,12	0,18	0,16
TERMALICA 600 T4/600-30/25/60 UZ	30	0,14	0,19	0,16
TERMALICA 500 T3/500-24/25/60 UZ	24	0,12	0,19	0,17
TERMALICA 600 T4/600-24/25/60 UZ	24	0,14	-	0,18
TERMALICA 600 T4/600-20/25/60 UZ	20	0,14	-	0,19
TERMALICA 700 T4/700-24/25/60 UZ*	24	0,18	-	0,19

*The thermal conductivity coefficient of the insulation material of $\lambda = 0.038$ W/mK

Inner walls

Load-bearing walls

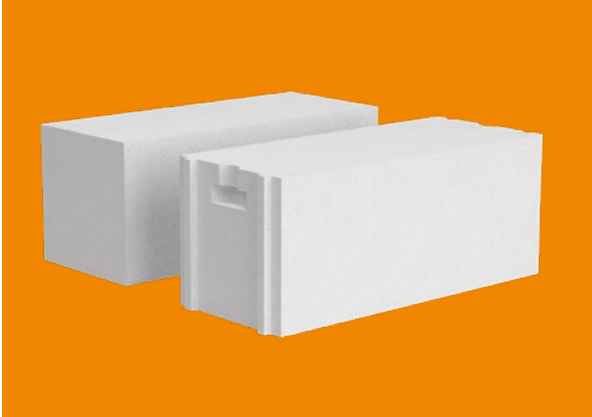

Internal load-bearing walls have the task of transferring the loads from higher storeys, ceilings and the roof to the foundations, and are used as bracing for the building. They are most commonly made of Termalica aerated concrete blocks of classes 500, 600 and 700 and a thickness of 24 cm.



Divider walls



Divider walls are constructional divisions separating individual rooms of a flat or building storey. Divider walls are usually made of Termalica blocks of classes 500, 600 or 700 and a thickness of 10 and 12 cm. The divider wall blocks have a smooth front surface or are equipped with a tongue and groove interlock. The walls are erected using thin-joint or traditional mortar. The porous structure and low weight of the aerated concrete blocks decidedly reduce ceiling loads in comparison to walls made of other masonry materials. The smooth and even surface of the walls made using thin-joint mortar permit the addition of tiles and cladding without prior smoothing and plastering of the surface, and the execution of thin-layer plaster

and gypsum finishing. Depending on the Termalica aerated concrete type, a 12-cm-thick wall as a RA1R acoustic insulation coefficient of 36-39 dB, and fulfils all standard requirements in terms of sound propagation insulation.

The most important advantage of divider walls made of Termalica aerated concrete is their lightness – low-weight components do not cause excess load and crowning of the ceilings. Thanks to this, aerated concrete divider walls can be used both in new as well as in refurbished buildings – because old structures require care in terms of load-bearing capacity.



Finishing and interior design panels

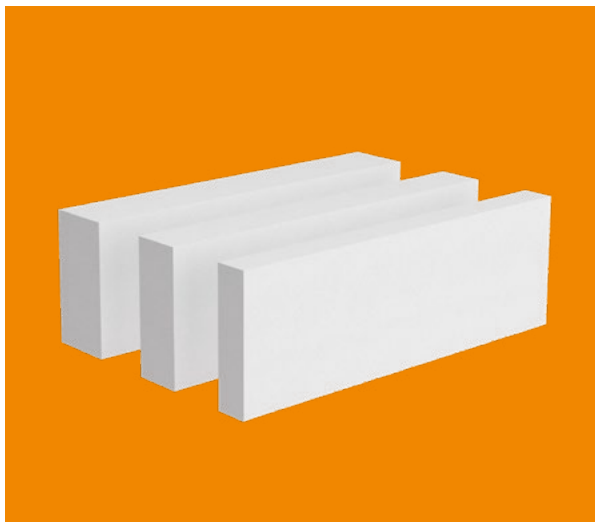

The 5, 7.5 and 10 cm-thick panels permit quick execution of refurbishment work and work on interior decoration, for instance:

- dividers and walls
- bathtub cladding
- shower walls
- fireplace housings
- kitchen and bathroom cupboards and shelves
- barbecue structures

The ease of processing permits the grinding and trimming of the material to any shape, which allows the execution of durable and interesting structures. The panels are made to highest precision class requirements (up to 1 mm), thanks to which they can be joined by thin-joint mortar or assembly foam, providing a smooth surface, and necessitating no plastering for ceramic cladding.

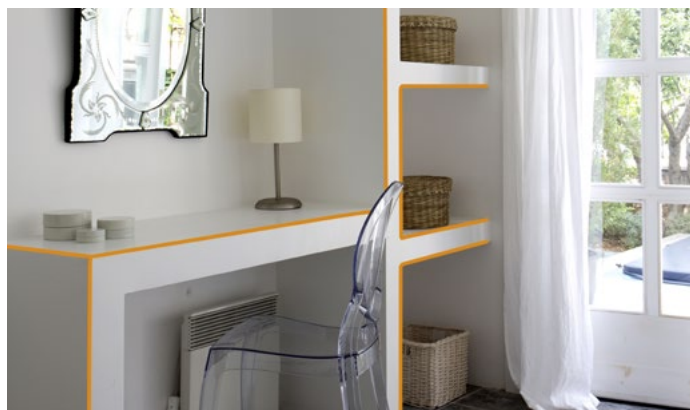
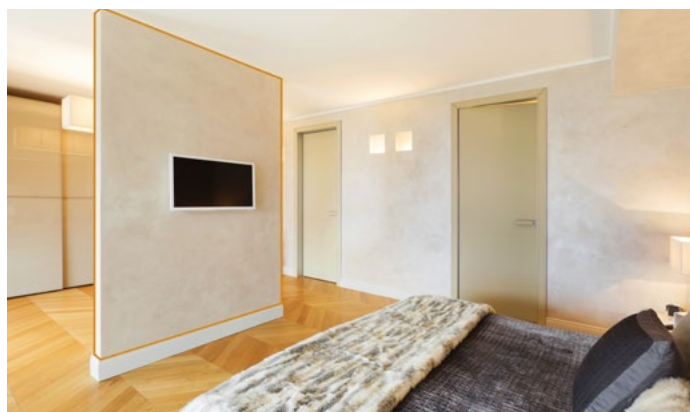

Cornice thermal insulation



Cornice thermal insulation components are aerated concrete blocks and mineral wool components having a thickness of 5 cm. These components function as lost formwork and thermal insulation of the reinforced concrete cornice of the ceiling on single-layer outer walls.



Lintels

Termalica lintels may be made of pre-cast reinforced slats or battens or U-profiles. The aerated concrete lintels, beside their structural function, help protect the walls from losing warmth. Together with the remaining components of the system – blocks and panels – they create a unified wall structure and reduce the emergence of thermal bridges.

Lintels require assembly formwork and support that is removed after the required strength of the mortar and filler concrete is achieved. The U-profile, thicker on one side, ensures appropriate thermal insulation of the lintel without the need for further insulation. They are available in two concrete density classes – 400 and 600 kg/cu m, in five width options. The fixed length of 599 mm and the height of 249 mm ensure that they fit perfectly with the remaining system components.



Termalica U-profiles

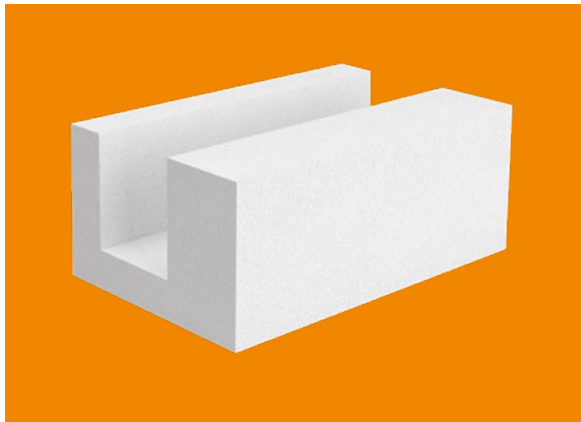

Termalica U-profiles function as lost formwork, and enable the construction of wall and door openings of large widths, such as terrace windows or garage doors. They can also be used for cornices, battens and reinforced concrete pillars, as well as wall reinforcement.

The U-profiles are filled with structural reinforcement, and then with concrete, so that a reinforced concrete core is created.

U-profile dimensions

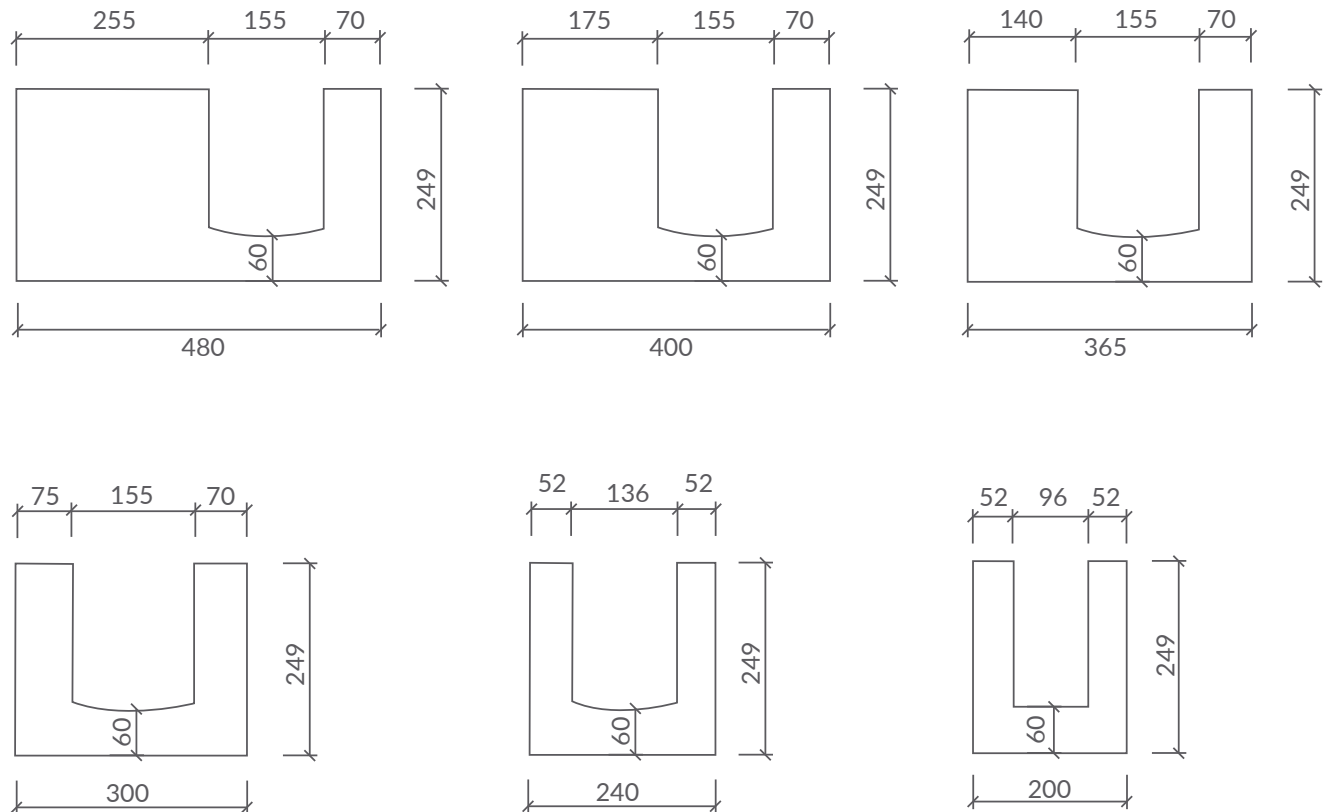

Termalica lintels

Termalica lintels are precast and reinforced aerated concrete components for the creation of lintels over window and door openings. Depending on the wall thickness, the battens are placed individually or two or three beside each other.

Termalica TNB lintels

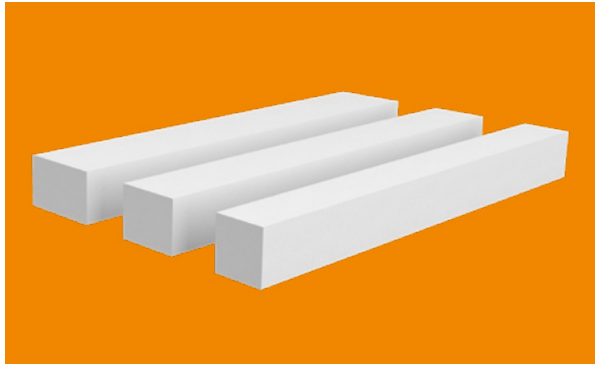

Termalica TNB lintels with a height of 12,4 cm are components used for the execution of joined lintels, whereby the lintels work together structurally with the wall they are to support. The maximum width of the opening to be covered is 2.50 m. The battens are available in three widths, 12, 15 and 20 cm. The full load bearing capacity of such a system lintel is achieved after the batten is covered with a layer of blocks, with their vertical joints filled by adhesive mortar, and following the execution of a reinforced concrete cornice at the ceiling level. The battens require assembly supports spaced out approx. 0.75 m, which can be removed seven days after the ceiling is concreted.

TERMALICA TNB LINTELS		
Length [cm]	Width[cm]	Height [cm]
120 - 300	12,4	12
		15
		20

Termalica TNN lintels

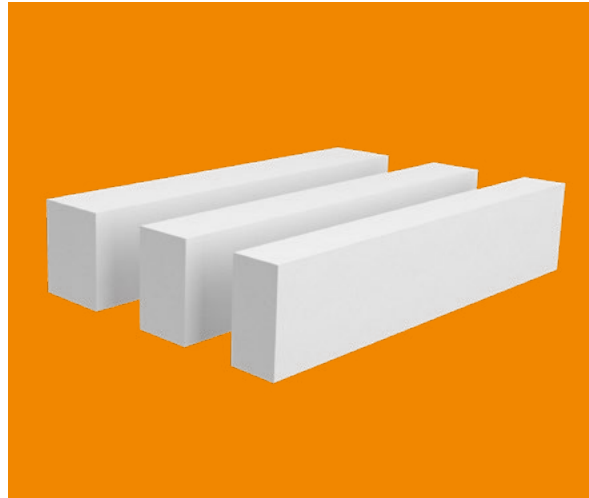

Termalica TNN lintels, with a height of 24,9 cm, are made of reinforced aerate concrete. Termalica TNN battens are independent structural components used for coverage of openings in outer, inner and divider walls, with a maximum opening width of 180 cm.

TERMALICA TNN LINTELS		
Length [cm]	Width [cm]	Height [cm]
120 - 230	24,9	12
		15
		20





Reinforced aerated concrete panels foreseen for the erection of walls and ceilings in industrial, commercial and retail sites.



TERMALICA® SPRINT

These large-size Termalica panels manufactured of reinforced aerated concrete are foreseen for the erection of ceilings and walls in single- and multi-family housing construction, as well as industrial and public buildings. The use of precast, custom-made Termalica Sprint panels and the elimination of any sort of formwork and support systems markedly reduces construction time.

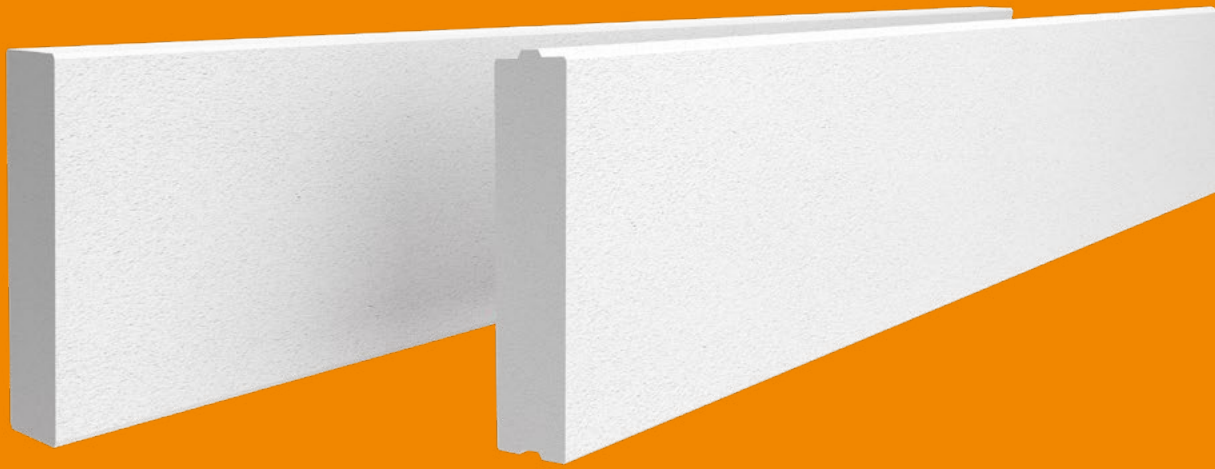

WALL PANEL DIMENSIONS

thickness [cm]	length [cm]	width [cm]
15	≤ 600 cm	≤ 60 cm
17,5		
20		
24		
30		

TERMALICA® SPRINT wall panels

The large-size **TERMALICA SPRINT** wall panels, made of reinforced aerated concrete, are used for the erection of protective outer walls and internal divider walls at industrial, retail and commercial sites.

The reinforced Termalica wall components are mounted to a building support structure made of precast steel or reinforced concrete transoms or pillars. Depending on the designed structural solution, the panels can be mounted in the outside, inside, or between pillars. The wall panels are fixed to the framework support structure using a system of connectors and anchors, depending on the support type.

The maximum spacing of load-bearing structural

components is six metres. Termalica wall components are manufactured of reinforced aerated concrete to resistance class AAC 4 and density of 600 kg/cu m.

The wall components are manufactured in two versions: with an interlocking tongue and groove profile and a smooth profile.

Wall panel cross section

Tongue and groove profile

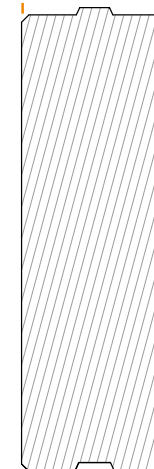

Smooth profile

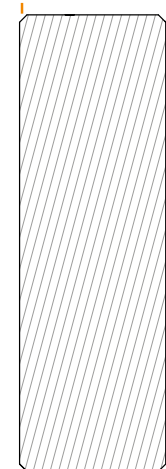

Advantages and technical properties

The reinforced **TERMALICA SPRINT** wall components are characterised by excellent thermal and acoustic insulation properties, and outstanding six-hour fire resistance – EI360 class.

Fire resistance

Wall divisions of aerated concrete are non-flammable (safest Euroclass, A1), and heat up much more slowly than other construction material, ensuring long-term protection of the stored materials, they are also fire-retardant. In case of walls with a specific fire resistance, use interlocking components, and additionally fill longitudinal joints with thin-joint mortar (despite the profiled edges).

Diagram of joining of the panels in case of necessary partition fire resistance

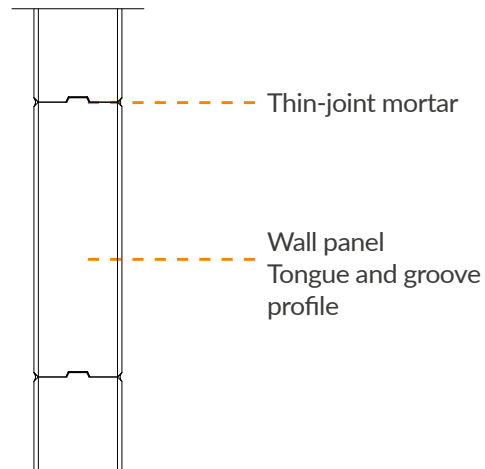

Heat permeation after six hours of fire

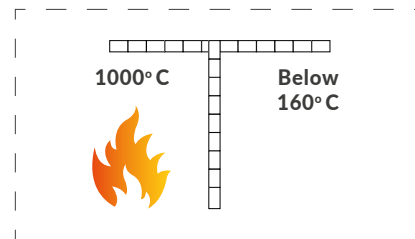

High fire resistance

Termalica panel partitions

- reduce the risk of fire spreading
- reduce the emergence of secondary fires
- release no toxic gases
- reduce the effect of explosions



High thermal insulation capabilities

- high heat accumulation
- stable internal atmosphere



Acoustic insulation properties



Fast and efficient assembly



Fast wall finishing

Wall panel technical parameters

1. Designations, resistance parameters and thermal insulation parameters

Component designation	Maximum volume density [kg/m ³]	Specific compression resistance [MPa]	Thermal conductivity coefficient $\lambda_{(10,D)}$ [W/mK]	Heat transfer coefficient U [W/m ² K]
TPO4/600-15	600	4,0	0,14	0,81
TPO4/600-17,5				0,704
TPO4/600-20				0,625
TPO4/600-24				0,53
TPO4/600-30				0,44

* The indicated U coefficient values factor in the heat reception resistance for walls, $R_{SE} = 0.04$, $R_{SI} = 0.13$

2. Fire resistance of non-load-bearing walls of Termalica reinforced concrete components per standard PN-EN 12602.

Component designation	Component thickness [mm]	Maximum component length [m]	Fire resistance
TPO4/600-15	150	6	EI 240
TPO4/600-17,5	175		EI 360
TPO4/600-20	200		EI 360
TPO4/600-24	240		EI 360
TPO4/600-30	300		EI 360

4. Fire resistance of impact-resistant walls of Termalica reinforced concrete components (REI-M) per standard PN-EN 12602.

Component designation	Component thickness [mm]	Maximum component length [m]	Fire resistance	
			Non-load-bearing walls	Load-bearing walls
TPO4/600-15	150	6	-	-
TPO4/600-17,5	175		EL-M90	-
TPO4/600-20	200		EL-M90	EL-M90
TPO4/600-24	240		EL-M120	EL-M90
TPO4/600-30	300		EL-M180	EL-M180

3. Fire resistance of load-bearing walls of Termalica reinforced concrete components per standard PN-EN 12602.

Component designation	Component thickness [mm]	Maximum component length [m]	Fire resistance
TPO4/600-15	150	6	REI 120
TPO4/600-17,5	175		REI 180
TPO4/600-20	200		REI 240
TPO4/600-24	240		REI 240
TPO4/600-30	300		REI 240

5. Acoustic insulation properties – proper R_{A1R} and R_{A2R} acoustic insulation evaluation values for plastered reinforced aerated concrete walls

Component designation	Component thickness [mm]	R_{A1R} [dB]	R_{A2R} [dB]
TPO4/600-15	150	40	36
TPO4/600-17,5	175	41	37
TPO4/600-20	200	43	40
TPO4/600-24	240	46	42
TPO4/600-30	300	48	45

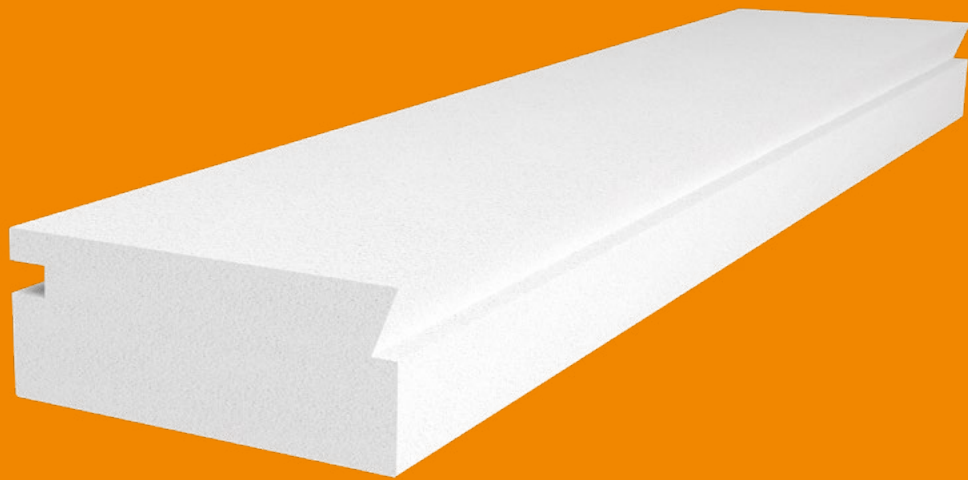

CEILING PANEL DIMENSIONS

thickness [cm]	length [cm]	width [cm]
24	≤ 600 cm	30-60
30		

Ceiling panel cross-section

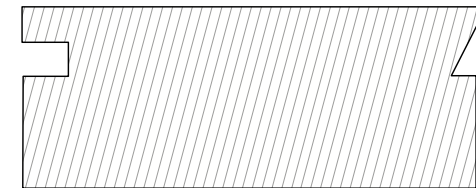

TERMALICA® SPRINT ceiling panels

Large-size Termalica ceiling panels, made of reinforced aerated concrete, are foreseen for the execution of ceilings in single- and multi-family residential construction, as well as in industrial and public sites.

The used of pre-cast, custom-made Termalica ceiling panels, as well as the elimination of formwork and assembly supports, markedly reduces the time of execution of a ceiling as compared to other technologies and ceiling systems.

The ceiling panels are laid out on the construction walls on a layer of Termalica adhesive mortar, and afterwards the specially profiled locking elements on the lengthwise sides of the panels are reinforced with 8-mm steel rods and filled with concrete together with wall cornices.

Ceilings made of Termalica panels require no process joints and can be loaded directly after conclusion of assembly, permitting further bricklaying or other work on subsequent storeys.

Termalica ceiling panels are manufactured of reinforced aerated concrete to resistance class AAC 4 and density of 600 kg/cu m.

The minimum support length a_0 of panels on supports – masonry, reinforced concrete and steel structure: 9 cm.

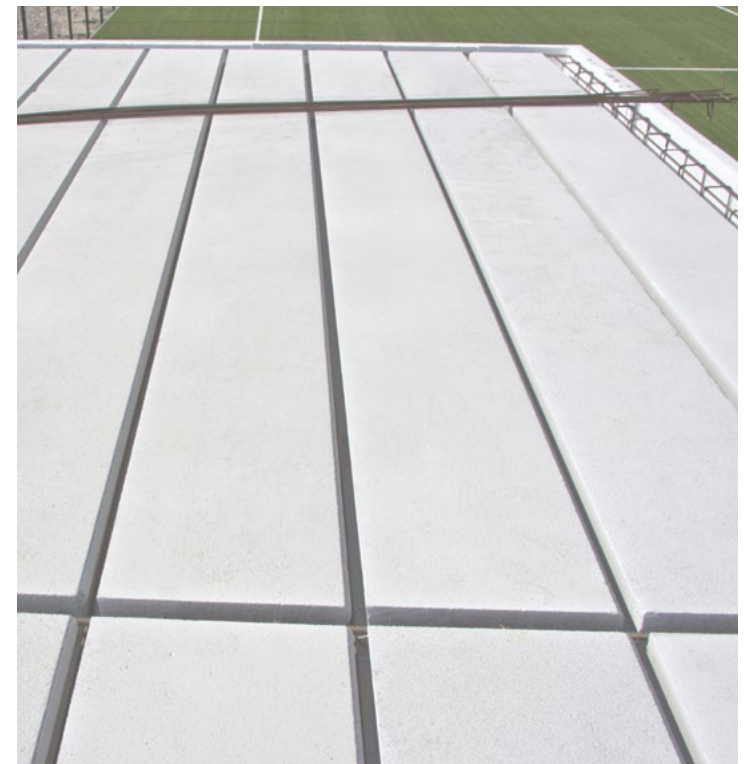

Ceiling panel technical parameters

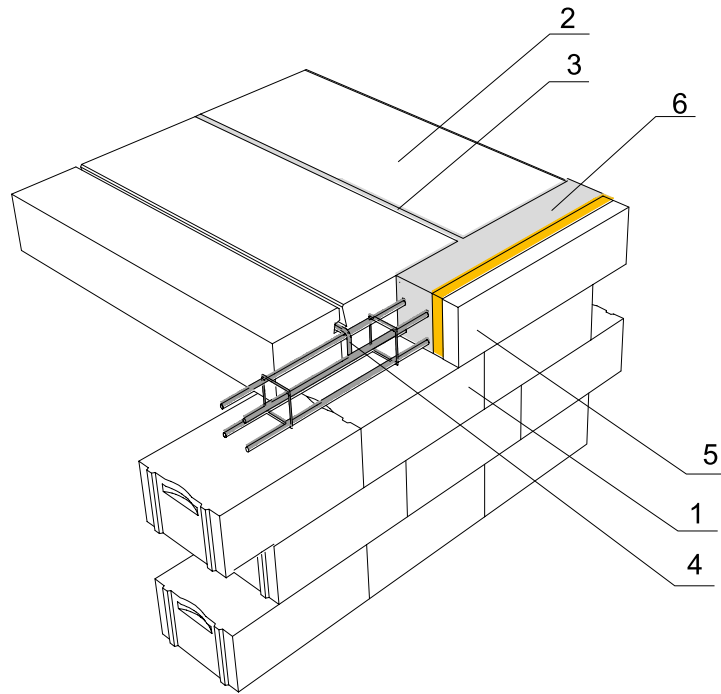

1. Termalica block wall
2. Termalica ceiling panel
3. Concrete filler material
4. Reinforcement between panels – 8 mm rod
5. Cornice thermal insulation
6. Ceiling cornice

1. Designations, resistance parameters and thermal insulation parameters.

Component designation	Maximum volume density [kg/m ³]	Specific compression resistance [MPa]	Thermal conductivity coefficient $\lambda(10,D)$ [W/mK]	Heat transfer coefficient U [W/m ² K]
TPS4/600-24	600	4,0	0,14	0,58
TPS4/600-30	600	4,0	0,14	0,58

2. Maximum panel lengths depending on calculational load exceeding own panel weight – placement on 90 mm support

Component designation	Panel thickness [cm]	Calculational load [kN/m ²] exceeding own panel weight						
		4,25	5,00	5,50	5,75	6,00	6,50	7,50
		Maximum panel length [m]						
TPS4/600-24	24	6,00	5,80	5,60	5,20	5,10	5,00	4,90
TPS4/600-30	30	6,00	5,80	5,60	5,20	5,10	5,00	4,90

4. Fire resistance of Termalica reinforced concrete ceiling panels per standard PN-EN 12602:2010.

Component designation	Panel thickness [cm]	Maximum component length [m]	Fire resistance
TPS4/600-24	24	6,0	REI 120
TPS4/600-30	30	6,0	REI 120

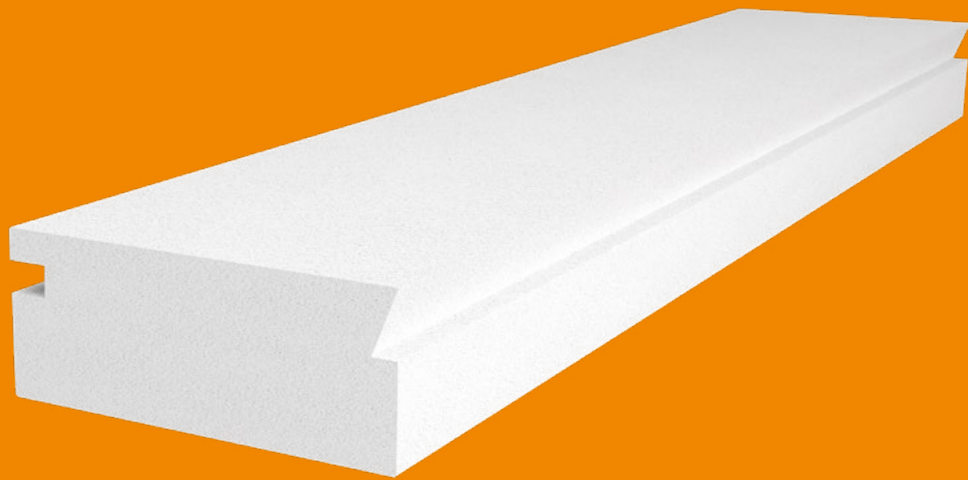

ROOF PANEL DIMENSIONS

thickness [cm]	length [cm]	width [cm]
24	≤ 600 cm	30-60
30		

TERMALICA® SPRINT roof panels

Large-size Termalica roof panels, made of reinforced aerated concrete, are foreseen for the execution of ceilings in single- and multi-family residential construction, as well as in industrial, retail and public sites.

The Termalica reinforced roof panels can be laid out on a wall, reinforced concrete structure or steel structure, creating a flat or inclined roof.

The used roof panels in residential housing construction permits the forgoing of use of traditional wooden roof A-frames. The panels rest on the building's load bearing walls. On the panels in turn, typical roof cladding is placed: humidity insulation, wooden battens of ca. 5 x 15 cm, between which thermal insulation is installed, to be followed by wind-resistant film, and battens in a cross arrangement, to be followed by metal sheet tiles or

ceramic tiles.

In case of structures with a pillar and transom structure made of precast steel or reinforced concrete components, the panels are laid out on roof battens and fixed to the structure by special connectors or a series of anchor rods.

The roof panels have a profiled side surface with a special filler inlet, foreseen for the placement of rebar and filling with concrete. On the inside, the panels can be plastered, clad in plasterboard or left unfinished (or just painted), with visible partitions into individual components and filling of lengthwise joints with a permanently elastic material.

Thanks to good thermal insulation properties and high thermal inertia, the use of Termalica panels ensures an appropriate atmosphere inside the rooms.

Roof panel cross-section

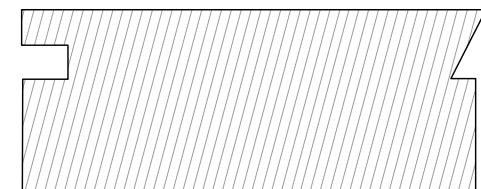

Termalica roof panels are manufactured of reinforced aerated concrete to resistance class AAC 4 and density of 600 kg/cu m.

The minimum support length a_0 of panels on supports – masonry, reinforced concrete and steel structure: 9 cm.

Roof panel technical parameters

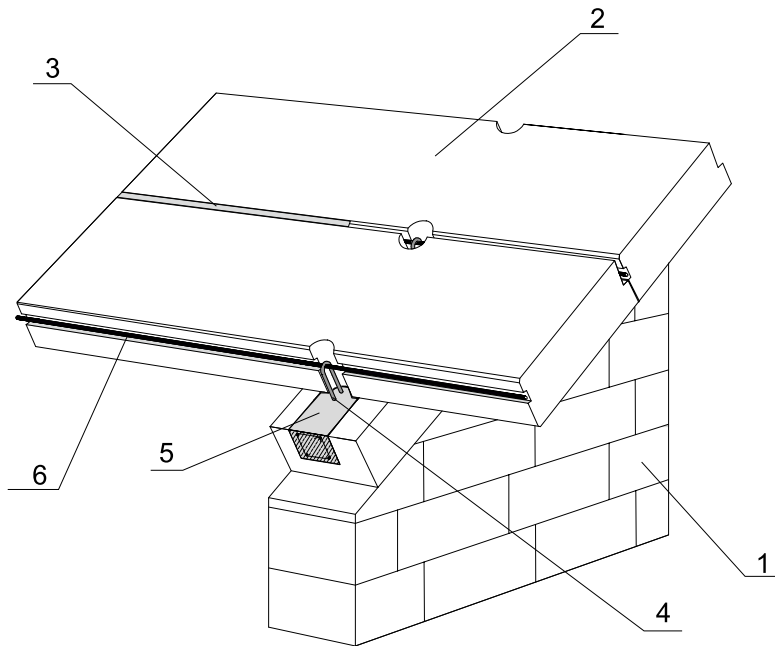

1. Termalica block wall
2. Termalica roof panel
3. Concrete filler material
4. Anchor reinforcement – 10 mm rod
5. U-profile cornice
6. Reinforcement between panels – 8 mm rod

1. Designations, resistance parameters and thermal insulation parameters

Component designation	Maximum volume density [kg/m ³]	Specific compression resistance [MPa]	Thermal conductivity coefficient $\lambda(10,D)$ [W/mK]	Heat transfer coefficient U [W/m ² K]
TPD4/600-24	600	4,0	0,14	0,58
TPD4/600-30	600	4,0	0,14	0,58

2. Maximum panel lengths depending on calculational load exceeding own panel weight – placement on 90 mm support

Component designation	Panel thickness [cm]	Calculational load [kN/m ²] exceeding own panel weight						
		4,25	5,00	5,50	5,75	6,00	6,50	7,50
		Maximum panel length [m]						
TPD4/600-24	24	6,00	5,80	5,60	5,20	5,10	5,00	4,90
TPD4/600-30	30	6,00	5,80	5,60	5,20	5,10	5,00	4,90

3. Fire resistance of roof panels of Termalica reinforced concrete components per standard PN-EN 12602:2010.

Component designation	Component thickness [cm]	Maximum component length [m]	Fire resistance
TPD4/600-24	24	6,0	REI 120
TPD4/600-30	30	6,0	REI 120

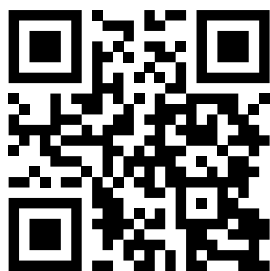

www.termalica.pl

Bruk-Bet is an official
Partner of the Association
of Polish Architects

